

# 1.25G Bi-Directional SFP Transceiver

## MBPD-2435M2D-C



### Features:

- 1310nm/1550nm single fiber bi-directional transmission
- Multi-Sourced SFP package with LC receptacle connector
- Operating bit rate 1.25Gbps
- Single +3.3V Power Supply
- Differential LVPECL inputs and outputs
- LVTTTL signal detect indicator
- Hot-pluggable capability

### Application:

- FTTx

### Description:

The MBPD-2435M2D-C series transceiver is high performance, cost effective module that supports data-rate of 1.25Gbps and transmission distance up to 40km.

As a transceiver, the transmitter section and the receiver section works individually in the module, the module features single mode single fiber bi-directional transmission obtained by an integrated WDM optical device. All these modules are supplied in the MSA (multi-source agreement) compliant SFP style package with a single LC receptacle connector.

The main application area of this module is optical data transmission system such as the P2P (Point-to-Point) FTTx optical access network.

### Specification:

| Operating Information |              |               |         |             |
|-----------------------|--------------|---------------|---------|-------------|
| Part Number           | Input/Output | Signal Detect | Voltage | Temperature |
| MBPD-2435M2           | AC/AC        | TTL           | +3.3V   | 0°C to70°C  |

| <b>Absolute Maximum Ratings</b> |        |      |        |      |      |
|---------------------------------|--------|------|--------|------|------|
| Parameter                       | Symbol | Min. | Max.   | Unit | Note |
| Storage Temperature             | $T_S$  | -40  | +85    | °C   |      |
| Operating Temperature           | $T_O$  | 0    | +70    | °C   |      |
| Soldering Temperature           |        |      | 260/10 | °C/s |      |

### **MBPD-2435M2D-C (1310nm DFB Tx/1550nm Rx, 40km)**

#### **Transmitter Optical, Electrical Characteristics**

| Parameter                           | Symbol          | Min. | Typ. | Max. | Unit     | Note          |
|-------------------------------------|-----------------|------|------|------|----------|---------------|
| Input Differential Impedance        | $R_{in}$        |      | 100  |      | $\Omega$ |               |
| Differential Data Input Swing       | $V_{in PP}$     | 100  |      | 1200 | mV       |               |
| Transmit Disable Input High Voltage |                 | 2.0  |      |      | V        |               |
| Transmit Disable Input Low Voltage  |                 |      |      | 0.8  | V        |               |
| Transmit Fault Output High Voltage  |                 | 2.0  |      |      | V        |               |
| Transmit Fault Output Low Voltage   |                 |      |      | 0.8  | V        |               |
| Transmit Disable Assert Time        |                 |      | 0.14 | 5    | $\mu s$  |               |
| Optical Transmit Power              | $P_O$           | -3   |      | 0    | dBm      | Average Power |
| Extinction Ratio                    | ER              | 8.5  |      |      | dB       |               |
| Central Wavelength                  | $\lambda_c$     | 1290 | 1310 | 1330 | nm       | 1.3um DFB     |
| Output Spectrum Width (-20dB)       | $\Delta\lambda$ |      |      | 1    | nm       | -20dB         |
| Side Mode Suppression Ratio         | SMSR            | 30   |      |      | dB       |               |
| Optical Isolation                   |                 | 30   |      |      | dB       |               |

#### **Receiver Optical, Electrical Characteristics**

| Parameter                                    | Symbol       | Min. | Typ. | Max. | Unit | Note      |
|--|--------------|------|------|------|------|-----------|
| Single Ended Data Output Swing               | $V_{out PP}$ | 200  |      | 800  | mV   |           |
| Receiver Loss of Signal Output Voltage -High |              | 2    |      |      | V    |           |
| Receiver Loss of Signal Output Voltage -Low  |              |      |      | 0.8  | V    |           |
| Sensitivity                                  | $Sen$        |      |      | -20  | dBm  | BER<1E-12 |
| Maximum Input Power                          | $P_{inMAX}$  | -3   |      |      | dBm  |           |
| Signal Detect Range                          |              | -35  |      | -21  | dBm  |           |
| Signal Detect-Hysteresis                     |              | 0.5  |      |      | dB   |           |

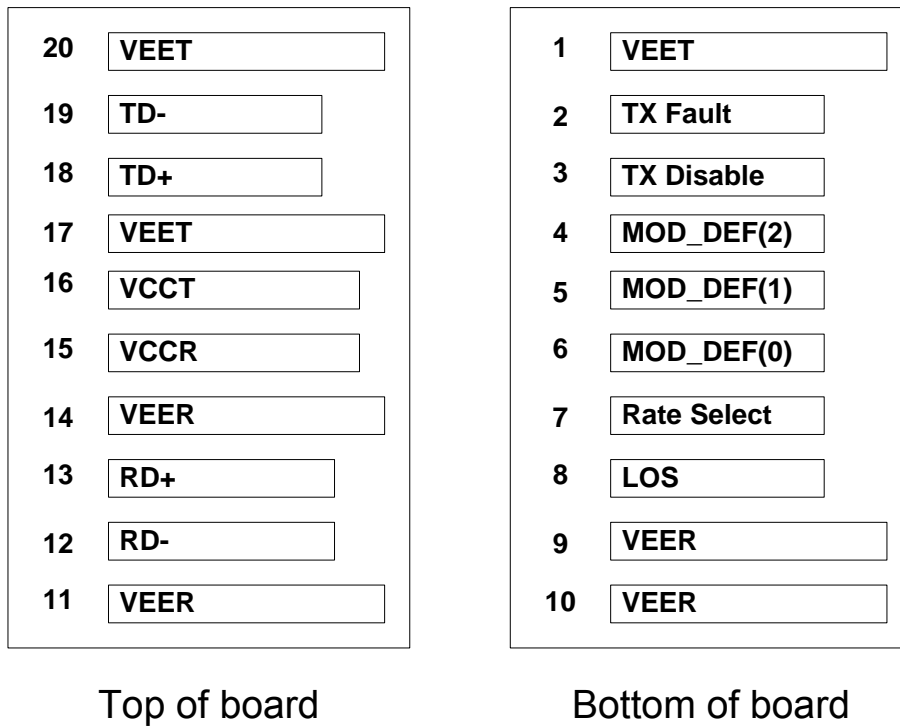
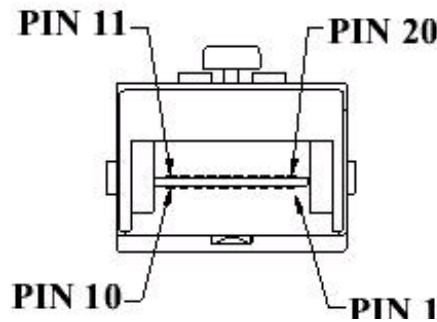
**Pin Definition:**

**Figure1**
**Pin Assignment:**

**Figure2**

| Pin | Name        | Description                 |
|-----|-------------|-----------------------------|
| 1   | VEET        | Transmitter Ground          |
| 2   | TXFAULT     | Transmitter Fault.          |
| 3   | TXDIS       | Transmitter Disable.        |
| 4   | MOD_DEF(2)  | SDA Serial Data Signal      |
| 5   | MOD_DEF(1)  | SCL Serial Clock Signal     |
| 6   | MOD_DEF(0)  | Grounded within the module. |
| 7   | Rate Select | No connection required      |

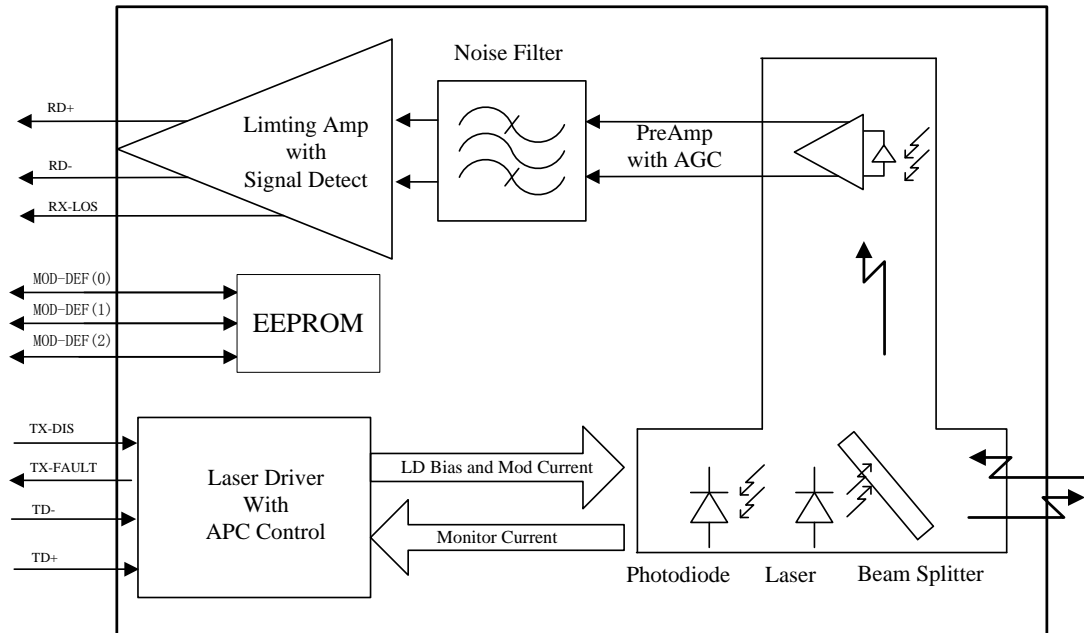
|    |      |  |
|----|------|--|
| 8  | LOS  | Loss of Signal indication. Logic 0 indicates normal operation. |
| 9  | VEER | Receiver Ground  |
| 10 | VEER | Receiver Ground  |
| 11 | VEER | Receiver Ground  |
| 12 | RD-  | Receiver Inverted DATA out.                                    |
| 13 | RD+  | Receiver Non-inverted DATA out.                                |
| 14 | VEER | Receiver Ground  |
| 15 | VCCR | Receiver Power Supply  |
| 16 | VCCT | Transmitter Power Supply                                       |
| 17 | VEET | Transmitter Ground   |
| 18 | TD+  | Transmitter Non-Inverted DATA in.                              |
| 19 | TD-  | Transmitter Inverted DATA in.                                  |
| 20 | VEET | Transmitter Ground   |

### Block Diagram Of Transceiver:



**Figure2**

## Transmitter Section

### TX-FAULT

The TTL level TX Fault is an open collector/drain output, which should be pulled up with a 4.7K – 10KΩ resistor on the host board. to VccT. When high, output indicates a laser fault of some kind. Low indicates normal operation. In the low state, the output will be pulled to < 0.8V.

When sensing an improper power level in the laser driver, the SFP sets this signal high and turns off the laser. TX-FAULT can be reset with the TX-DISABLE line.

### TX-DISABLE

TX disable is an input that is used to shut down the transmitter optical output. It is pulled up within the module with a 4.7 – 10 KΩ resistor. The states are:

- Low (0 – 0.8V): Transmitter on;
- (>0.8, < 2.0V): Undefined;
- High (>2.0): Transmitter Disabled;
- Open: Transmitter Disabled.

Make TX-DISABLE high (TTL logic “1”) to turn off the laser output. The laser will turn on when TX-DISABLE is low (TTL logic “0”).

### TD-/+

TD-/+ is AC-coupled 100Ω differential transmitter inputs. These inputs will accept differential swings of 500 –1600 mV (250 –800 mV single-ended).

## Receiver Section

### RX-LOS

The TTL level RX-LOS signal is an open collector/drain output, which should be pulled up with a 4.7K – 10KΩ resistor to VccR. When high, this output indicates the received optical power is below the worst-case receiver sensitivity level. Low indicates normal operation. In the low state, the output will be pulled to < 0.8V.

**RD-/+**

RD-/+ are AC coupled 100Ω differential outputs which should be terminated with 100 Ω(differentially) at the user SERDES. The AC coupling is done inside the module and is thus not required on the host board. The voltage swing on these lines will be between 400 and 1600 mV differential (200 – 800 mV single ended) when properly terminated.

**Recommended Interface Circuit:**

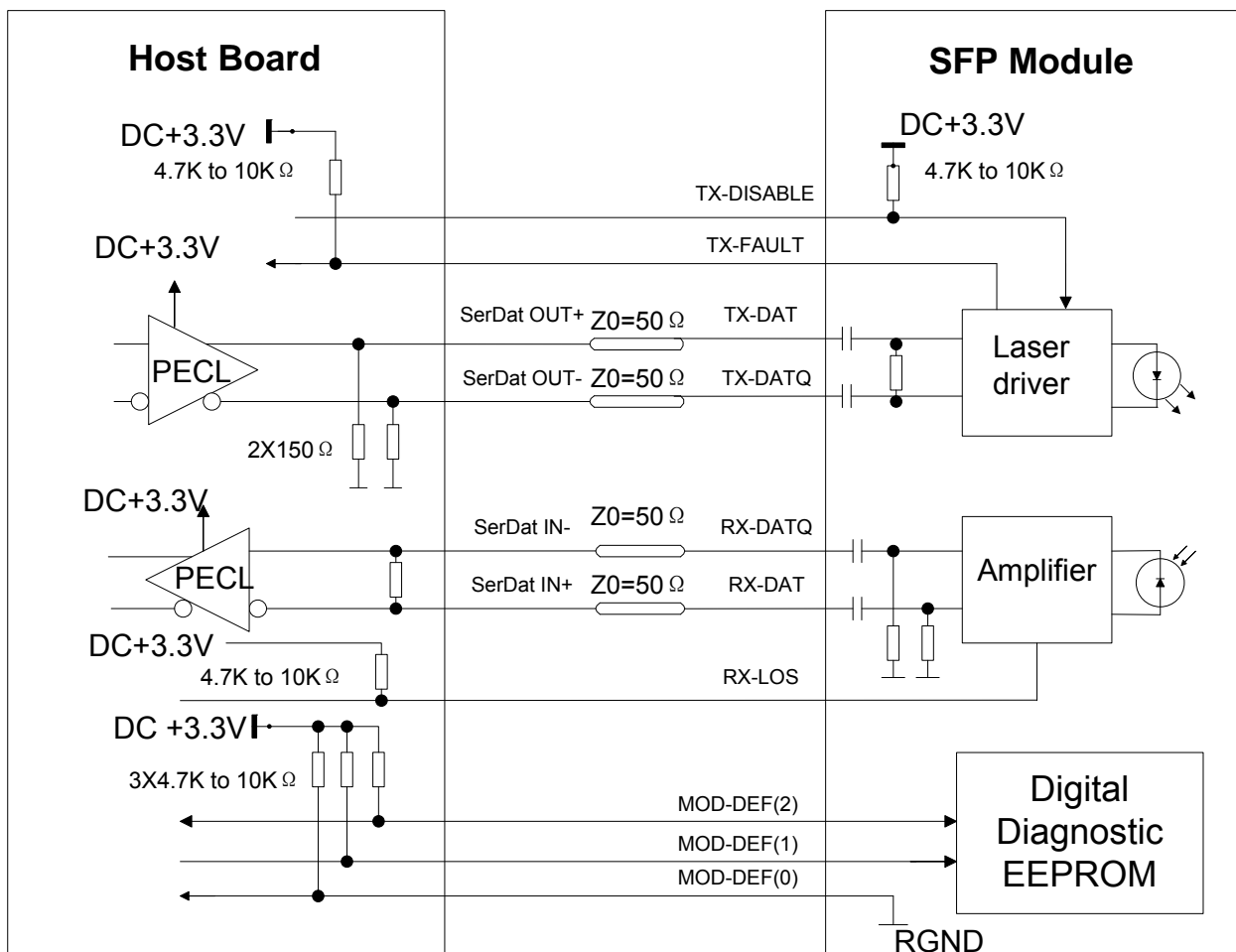

**Figure4**

**Dimensions:**

Dimensions are in millimeters. All dimensions are  $\pm 0.1\text{mm}$  unless otherwise specified. (unit:mm).

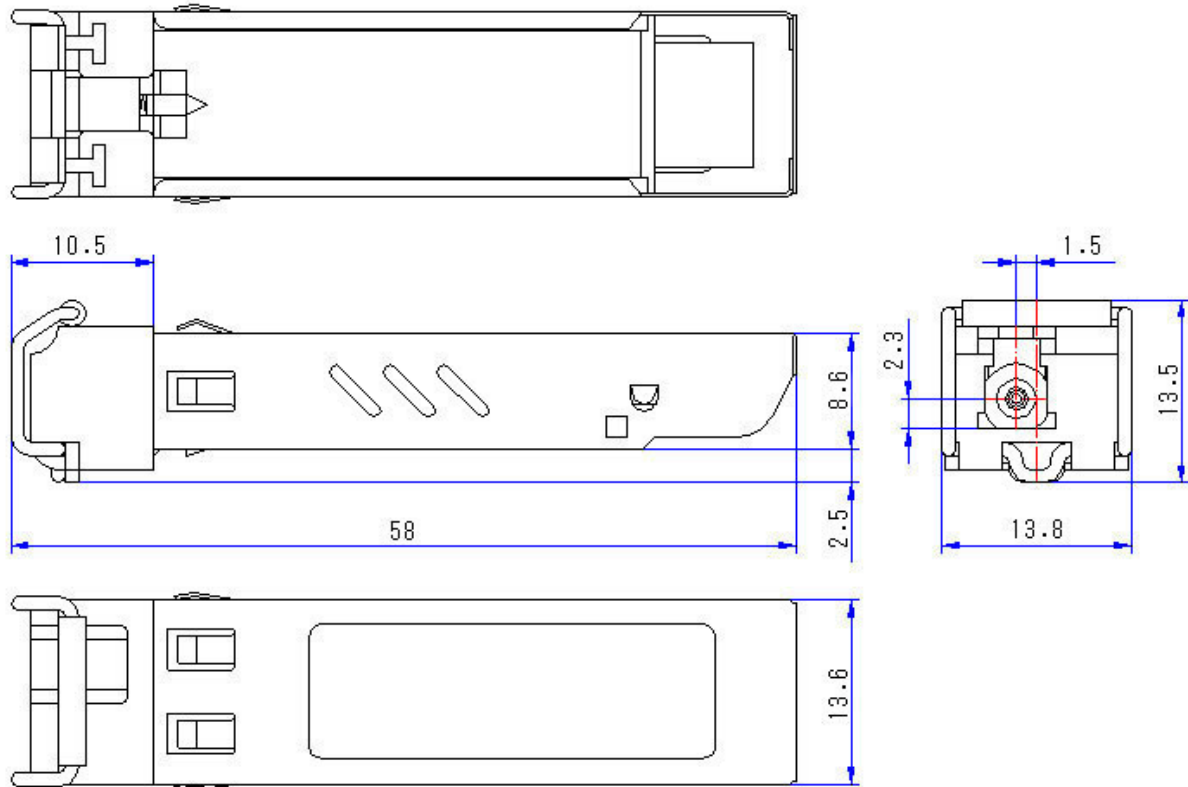

**Figure5**

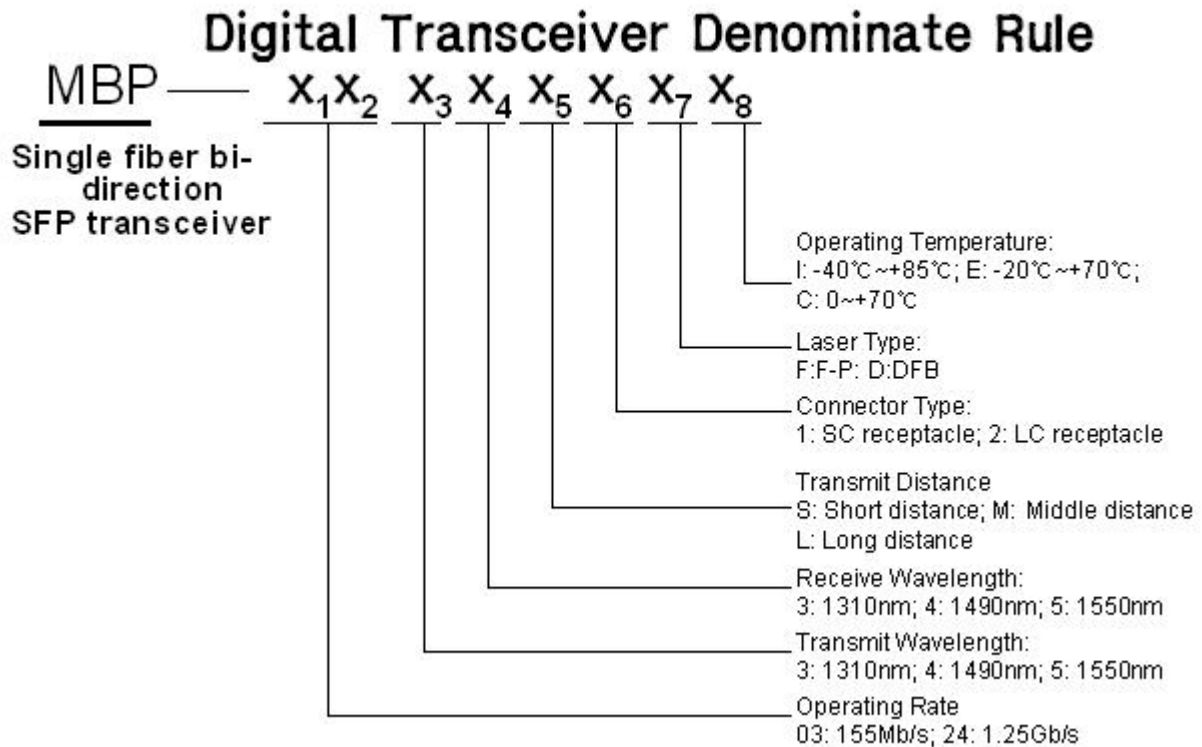
**Ordering Information:**

**Statement:**

HG Genuine possesses the authority for ultimate explanation of all information contained in this document, which is subject to change without prior notice. All the information was obtained in specific environments; and HG Genuine will not be responsible for verifying the products performance in customers' operating environments, neither liable for the performance of users' products. All information contained is only for the users' reference and shall not be considered as warranted characteristics.. HG Genuine will not be liable for damages arising directly or indirectly from any use of the information contained in this document.

Version: **V1.0**

Publishing Date: 2006-05-15

**Contact Information:**

Address: HUST Science & Technology Park, East Lake Hi-Tech Development Zone, Wuhan, Hubei 430223, China.

Tel: +86-27-87180102

Website: <http://www.genuine-opto.com>