

155Mbps SFP Multimode Transceiver

MXP-033SH



Features:

- Operating data rate 155Mbps
- Industry standard Small Form Pluggable (SFP) package
- Duplex LC connector
- 2km transmission distance with MMF
- Single +3.3V power supply
- Differential LVPECL inputs and outputs
- TTL signal detect indicator
- Hot-pluggable capability

Application:

- SDH STM-1/SONET OC-3
- Fast Ethernet
- Other optical links

Description:

MXP-033SH series is transceiver compliant with SFP MSA. This series features high performance at low cost, and provides users a cost effective selection for data rate up to 155Mbps.

The transmitter section and the receiver section work independently in the transceiver. The receiver section contains an InGaAs PIN photo diode, a transimpedance amplifier and a post amplifier (with working data rate up to 155Mbps), functionally transmit received optical power to steady electrical data. The transmitter section contains a 1310nm laser diode with back-facet monitor and a laser driver with APC function, transmit input electrical data to steady optical output signal.

MXP-033SH provides users a complete selection for different transmission distance to 2km. The product is compliant with the SFP MSA such as the LC optical interface receptacle, 3.3V supply voltage, TTL signal detect logic.

Specification:

Operating Information				
Part Number	Input/Output	Signal Detect	Voltage	Temperature
MXP-033SH	AC/AC	TTL	+3.3V	0°C ~ 70°C

Absolute Maximum Ratings

Parameter	Symbol	Min.	Max.	Unit	Note
Storage Temperature	T_S	-40	+85	°C	
Power Supply Voltage	V_{CC}	-0.5	5.0	V	

Recommended Operating Conditions

Parameter	Symbol	Min.	Typ.	Max.	Unit	Note
Operating Temperature	T_O	0	+25	+70	V	
Power Supply Voltage	V_{CC}	3.13	3.3	3.47	V	
Power Supply Current	I_{CC}			300	mA	

MXP-033SH (1310nm FP and PIN, 2km)
Transmitter Optical, Electrical Characteristics

Parameter	Symbol	Min.	Typ.	Max.	Unit	Note
Input Differential Impedance	R_{in}		100		Ω	
Transmitter Differential Input Voltage	$V_{in PP}$	500		1200	mV	
Transmit Disable Input High Voltage		2.0			V	
Transmit Disable Input Low Voltage				0.8	V	
Optical Transmit Power	P_O	-20		-14	dBm	
Extinction Ratio	ER	9			dB	
Central Wavelength	λ_c	1270		1380	nm	
Output Spectrum Width (FWHM)	$\Delta\lambda$			7.7	nm	

Receiver Optical, Electrical Characteristics

Parameter	Symbol	Min.	Typ.	Max.	Unit	Note
Receiver Differential Output Voltage	$V_{out PP}$	400		1600	mV	
Receiver Loss of Signal Output Voltage-High		2.0			V	
Receiver Loss of Signal Output Voltage-Low				0.8	V	
Sensitivity	Sen			-31	dBm	
Maximum Input Power	P_{inMAX}	-3			dBm	
Signal Detect Range		-45		-32	dBm	
Signal Detect-Hysteresis		0.5			dB	
Total Jitter	T_J			0.43	UI	
Central Wavelength	λ_c	1260		1620	nm	

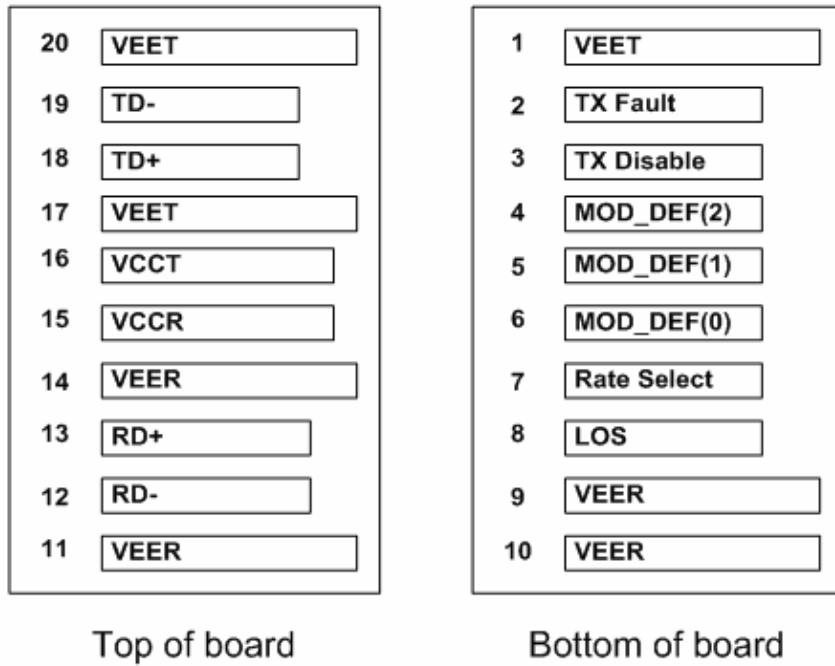
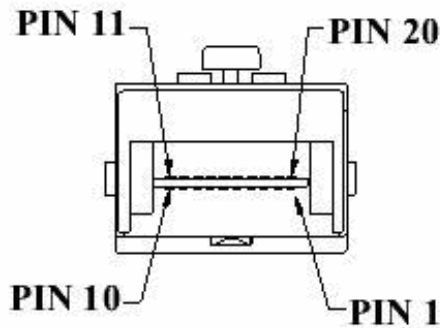
Pin Definition:

Figure1
Pin Assignment:

Figure2

Pin	Name	Description
1	VEET	Transmitter Ground.
2	TXFAULT	Transmitter Fault , connected to Ground.
3	TXDIS	Transmitter Disable.
4	MOD_DEF(2)	SDA Serial Data Signal.
5	MOD_DEF(1)	SCL Serial Clock Signal.
6	MOD_DEF(0)	Grounded within the module.
7	Rate Select	No connection required.
8	LOS	Loss of Signal indication. Logic 0 indicates normal operation.

9	VEER	Receiver Ground.
10	VEER	Receiver Ground.
11	VEER	Receiver Ground.
12	RD-	Receiver Inverted DATA out.
13	RD+	Receiver Non-inverted DATA out.
14	VEER	Receiver Ground.
15	VCCR	Receiver Power Supply.
16	VCCT	Transmitter Power Supply.
17	VEET	Transmitter Ground.
18	TD+	Transmitter Non-Inverted DATA in.
19	TD-	Transmitter Inverted DATA in.
20	VEET	Transmitter Ground.

Block Diagram Of Transceiver

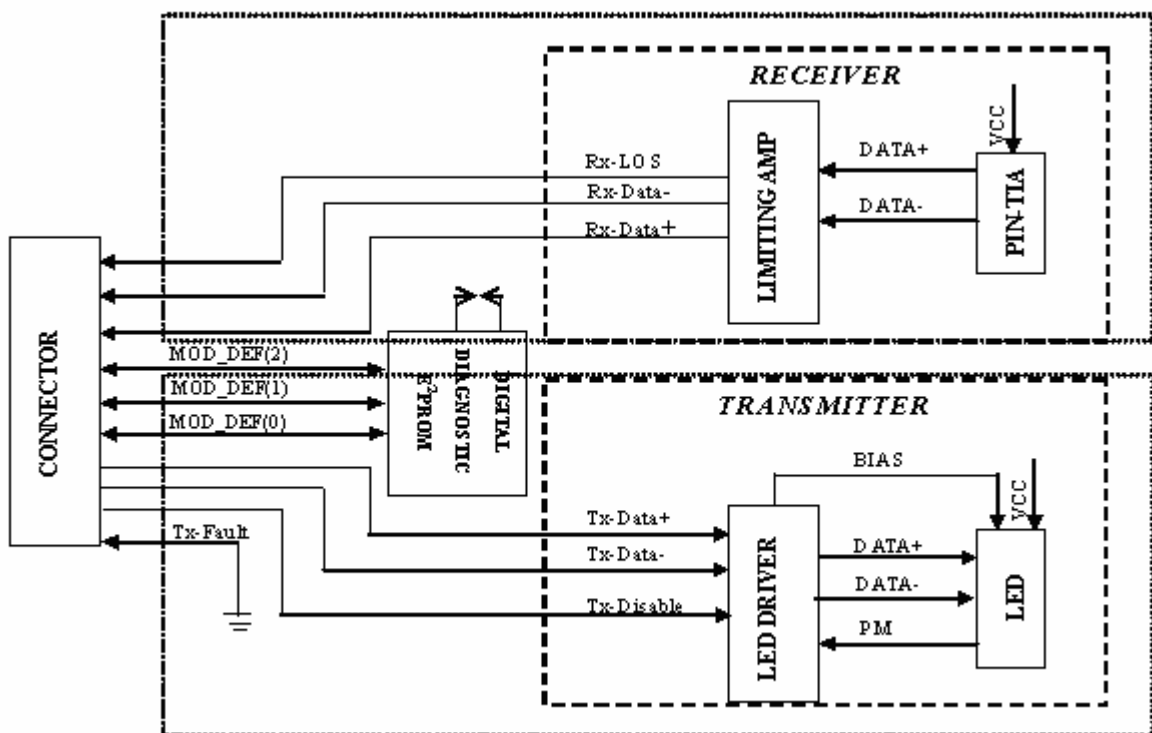

Figure3

Transmitter Section**TX-FAULT**

TX Fault is an open collector/drain output, which should be pulled up with a 4.7K – 10K Ω resistor on the host board. Pull up voltage between 2.0V and VccT, R+0.3V. When high, output indicates a laser fault of some kind. Low indicates normal operation. In the low state, the output will be pulled to < 0.8V.

When sensing an improper power level in the laser driver, the SFP sets this signal high and turns off the laser. TX-FAULT can be reset with the TX-DISABLE line. The signal is in TTL level.

TX-DISABLE

TX disable is an input that is used to shut down the transmitter optical output. It is pulled up within the module with a 4.7 – 10 K Ω resistor. Its states are: Low (0 – 0.8V): Transmitter on; (>0.8, < 2.0V): Undefined; High (2.0 – 3.465V): Transmitter Disabled; Open: Transmitter Disabled. The TX-DISABLE signal is high (TTL logic “1”) to turn off the laser output. The laser will turn on when TX-DISABLE is low (TTL logic “0”).

TD-/+

These are the differential transmitter inputs. They are AC-coupled, differential lines with 100 Ω differential termination inside the module. The AC coupling is done inside the module and is thus not required on the host board. The inputs will accept differential swings of 500 – 2400 mV (250 – 1200 mV single-ended), though it is recommended that values between 500 and 1200 mV differential (250 – 600 mV single-ended) be used for best EMI performance.

Receiver Section**RX-LOS**

LOS (Loss of Signal) is an open collector/drain output, which should be pulled up with a 4.7K – 10K Ω resistor. Pull up voltage between 2.0V and VccT, R+0.3V. When high, this output indicates the received optical power is below the worst-case receiver sensitivity (as defined by the standard in use). Low indicates normal operation. In the low state, the output will be pulled to < 0.8V.

The RX-LOS is high (TTL logic “1”) when there is no incoming light from the companion transceiver. This signal is normally used by the system for the diagnostic purpose. The signal is operated in TTL level.

RD-/+

These are the differential receiver outputs. They are AC coupled 100 Ω differential lines which should be terminated with 100 Ω (differential) at the user SERDES. The AC coupling is done inside the module and is thus not required on the host board. The voltage swing on these lines will be between 370 and 2000 mV differential (185 – 1000 mV single ended) when properly terminated.

Mod-Def 0, 1, 2.

Mod-Def 0, 1, 2. These are the module definition pins. They should be pulled up with a 4.7 - 10K resistor on the host board to supply less than $V_{ccT}+0.3V$ or $V_{ccR}+0.3V$.

Mod-Def 0 is grounded by the module to indicate that the module is present.

Mod-Def 1 is clock line of two wire serial interface for optional serial ID.

Mod-Def 2 is data line of two wire serial interface for optional serial ID.

Recommended Interface Circuit:

Figure4

Dimensions:

Dimensions are in millimeters. All dimensions are ± 0.1 mm unless otherwise specified. (Unit: mm)

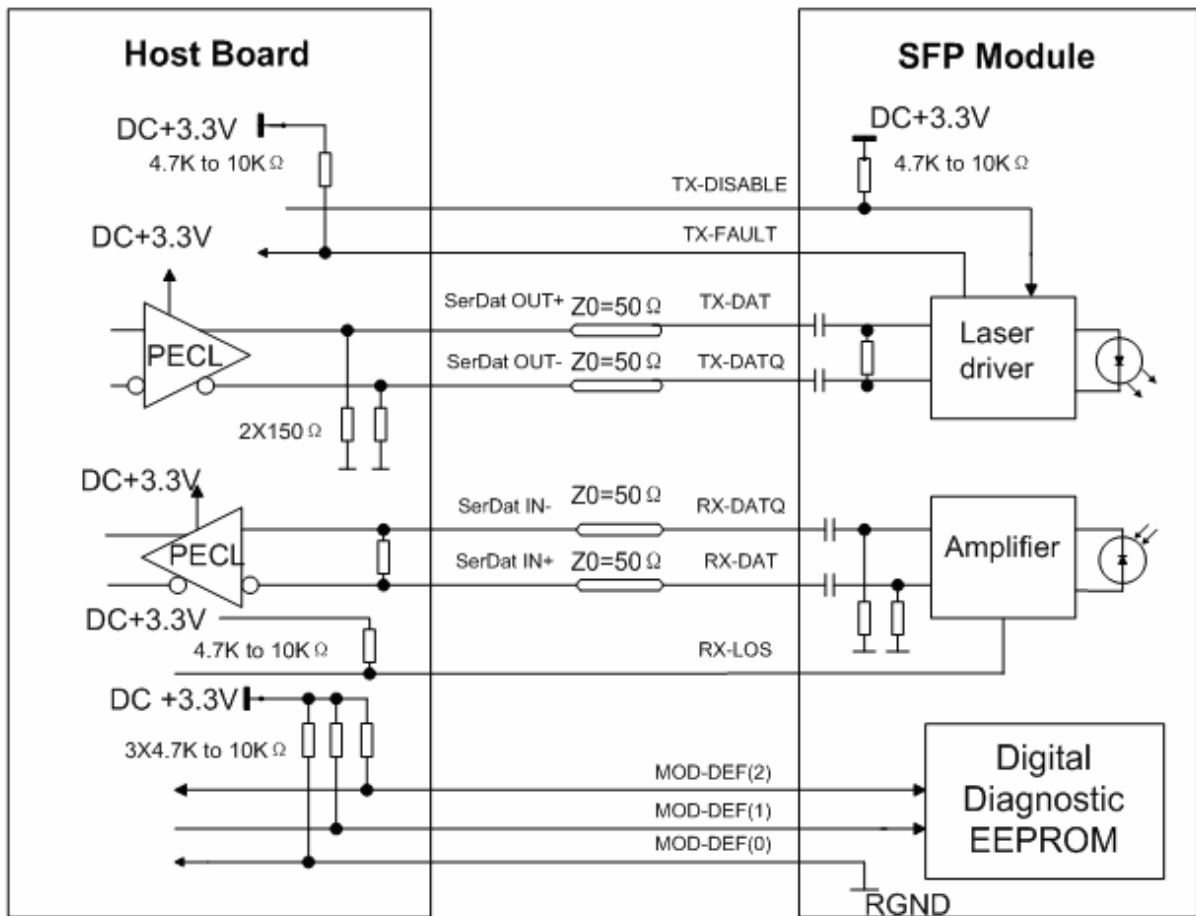
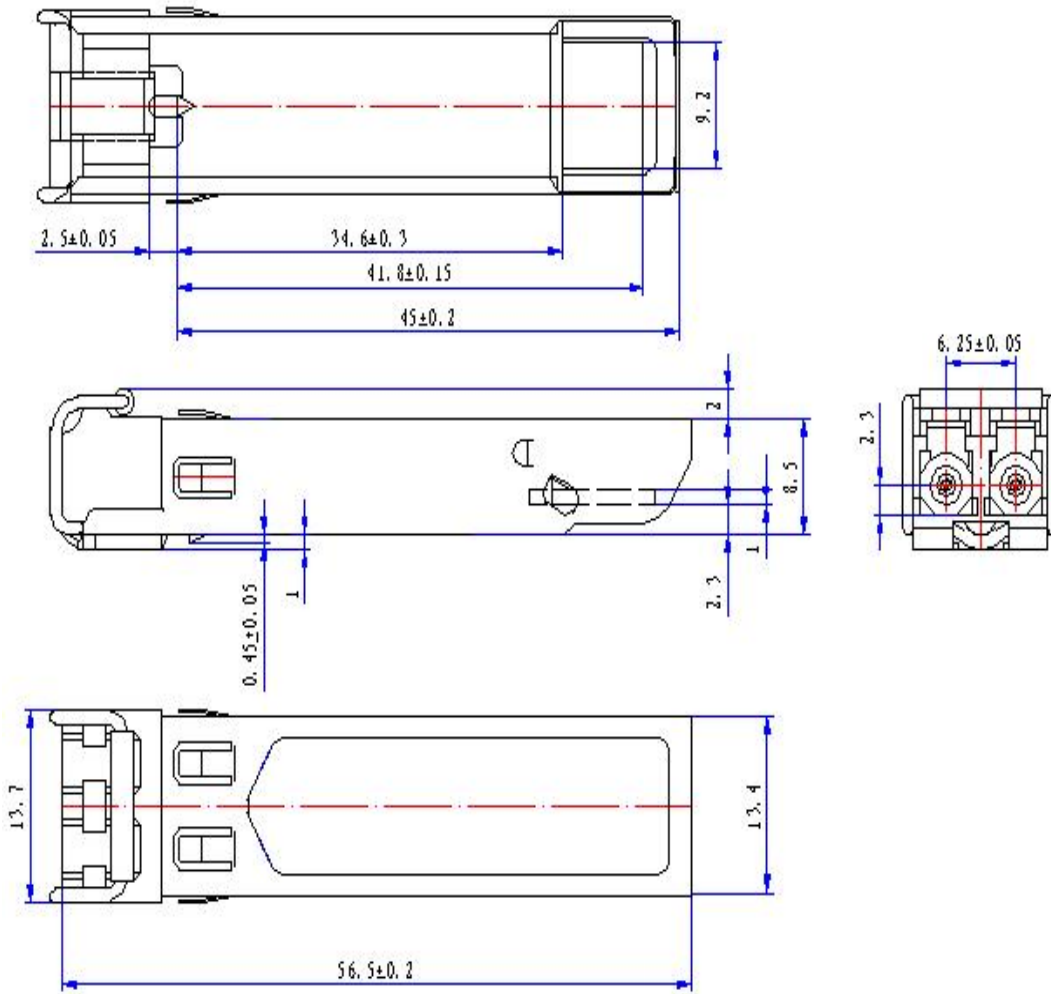
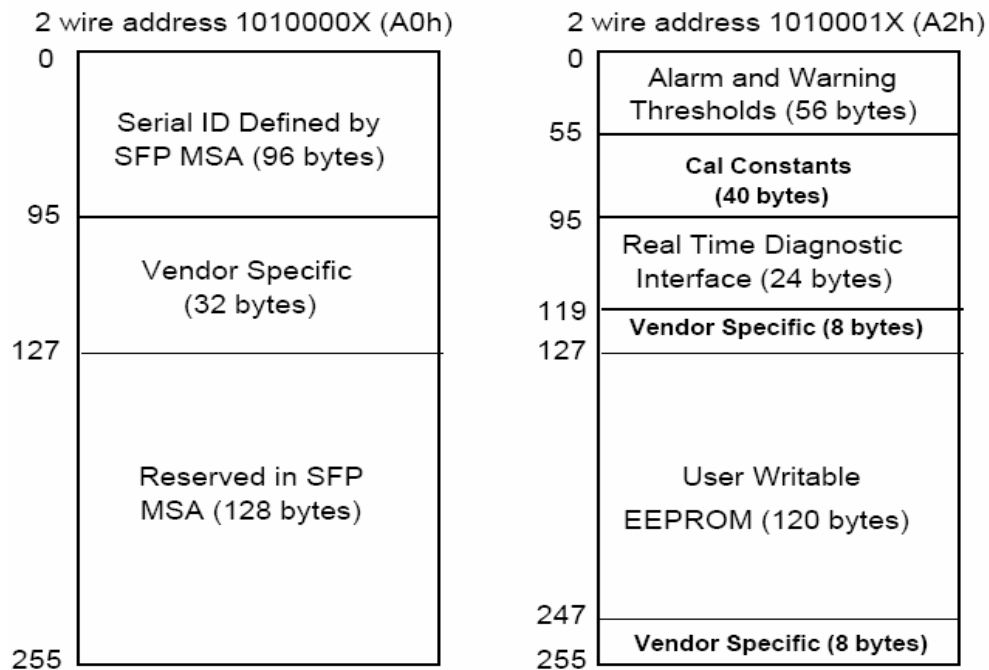

Figure5

Digital Diagnostic Memory Map:

EEPROM Serial ID Memory Contents:

Accessing Serial ID Memory uses the 2 wire address 1010000X (A0). Memory Contents of Serial ID are shown in the table below:

MXP-033SH (1310nm FP and PIN, 2Km)

Data Address	Size (Bytes)	Name of Field	Contents(Hex)	Description
BASE ID FIELDS				
0	1	Identifier	03	SFP
1	1	Ext. Identifier	04	SFP function is defined by serial ID only
2	1	Connector	07	LC Connector
3-10	8	Transceiver	00 00 01 00 00 00 00 00	Transceiver Codes
11	1	Encoding	05	
12	1	BR, Nominal	01	155 Mbps
13	1	Reserved	00	
14	1	Length(9um,km)	00	Not compliant
15	1	Length (9um)	00	
16	1	Length (50um)	02	Transceiver transmit distance (2Km)
17	1	Length (62.5um)	00	

18	1	Length (Copper)	00	Not compliant
19	1	Reserved	00	
20-35	16	Vendor name	48 47 20 47 45 4E 55 49 4E 45 20 20 20 20 20 20	“HG GENUINE” (ASCII)
36	1	Reserved	00	
37-39	3	Vendor OUI	00 00 00	
40-55	16	Vendor PN	4D 58 50 2D 30 33 33 53 48 20 20 20 20 20 20 20	“MXP-033SH” (ASCII)
56-59	4	Vendor rev	00 00 00 00	
60-61	2	Wavelength	00 00	Transceiver wavelength
62	1	Reserved	00	
63	1	CC_BASE	Check Sum (Variable)	Check code for Base ID Fields
EXTENDED ID FIELDS				
64-65	2	Options	00 1A	TX_DISABLE, TX_FAULT and Loss of Signal implemented.
66	1	BR, max	00	
67	1	BR, min	00	
68-83	16	Vendor SN	20 20 20 20 20 20 20 20 38 37 36 35 34 33 32 31	Serial Number of transceiver (ASCII). For example “87654321”.
84-91	8	Date code	30 34 31 32 30 35 20 20	Manufactory date code. For example “041205”.
92	1	Diagnostic Monitoring Type	00	Diagnostics (Ext.Cal)
93	1	Enhanced Options	00	Diagnostics (Optional Alarm/warning flags, Soft TX_FAULT and RX_LOS monitoring)
94	1	SFF-8472 Compliance	00	Diagnostics (SFF-8472 Rev 9.4)
95	1	CC_EXT	Check Sum (Variable)	Check sum for Extended ID Field.
VENDOR SPECIFIC ID FIELDS				
96-255	160	Vendor Specific		

Ordering Information:

Digital Transceiver Denominate Rule

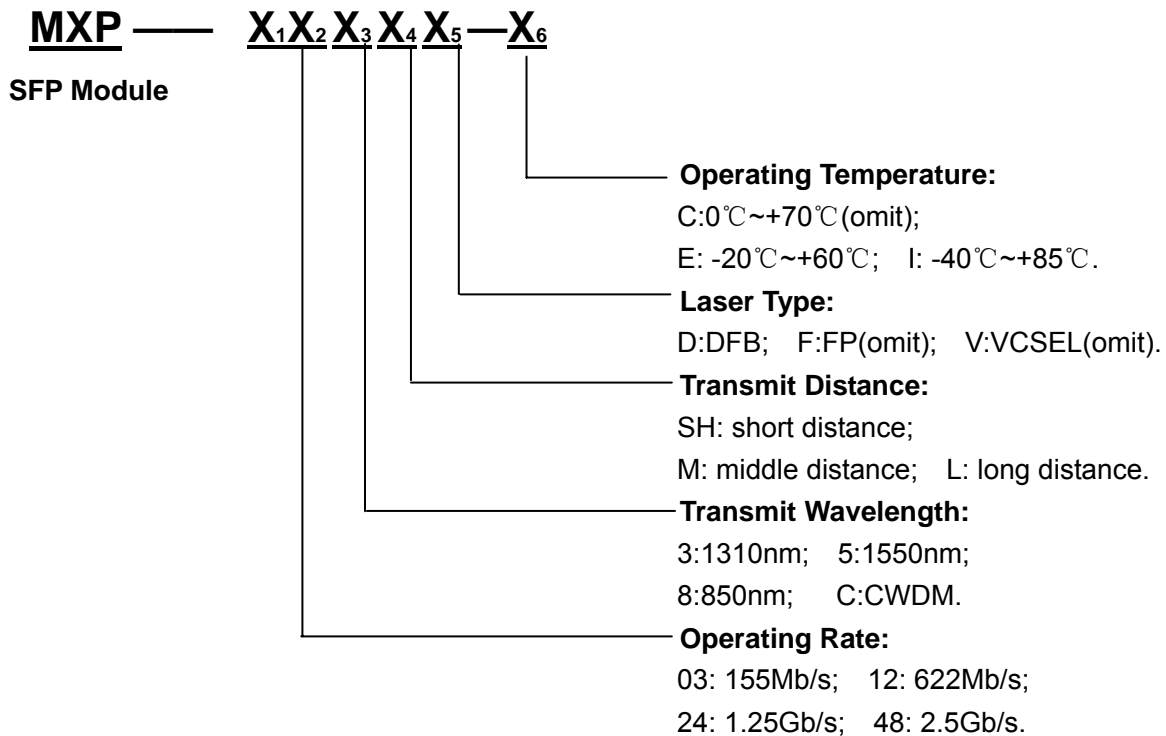
Statement:

HG Genuine possesses the authority for ultimate explanation of all information contained in this document, which is subject to change without prior notice. All the information was obtained in specific environments; and HG Genuine will not be responsible for verifying the products performance in customers' operating environments, neither liable for the performance of users' products. All information contained is only for the users' reference and shall not be considered as warranted characteristics. HG Genuine will not be liable for damages arising directly or indirectly from any use of the information contained in this document.

Version: **V1.1**

Publishing Date: 2007-04-16

Contact Information:

Address: HUST Science & Technology Park, East Lake Hi-Tech Development Zone, Wuhan, Hubei 430223, China.

Tel: +86-27-87180102

Website: <http://www.genuine-opto.com>