

1250Mbps SFP Transceiver With Digital Diagnostic Function MXPD-245MD



Features:

- Operating data rate 1250Mbps
- Industry standard Small Form Pluggable (SFP) package
- Digital diagnostic monitor interface compliant with SFF-8472
- Duplex LC connector
- Up to 40km transmission distance
- Single +3.3V power supply
- Differential LVPECL inputs and outputs
- TTL signal detect indicator
- Hot-pluggable capability

Application:

- Switch to Switch interface
- Switched backplane applications
- Router/Server interface
- Other optical transmission systems

Description:

The MXPD-245MD series transceiver is high performance, cost effective module that supports data-rate of 1250Mbps and transmission distance from to 40km.

The transceiver meets the Small Form Pluggable (SFP) industry standard package utilizing an integral LC-Duplex optical interface connector. The hot pluggable capability of the SFP package allows the module to be installed at any time - even with the host system operating and on-line. An enhanced Digital Diagnostic Monitoring Interface compliant with SFF-8472 has been incorporated into the transceiver. It allows real time access to the transceiver operating parameters such as transceiver temperature, laser bias current, transmitted optical power, received optical power and transceiver supply voltage by reading a built-in memory with I²C interface.

Specification:

Operating Information				
Part Number	Input/Output	Signal Detect	Voltage	Temperature
MXPD-245MD	AC/AC	TTL	+3.3V	0°C ~ 70°C

Absolute Maximum Ratings

Parameter	Symbol	Min.	Max.	Unit	Note
Storage Temperature	T_S	-40	+85	°C	
Operating Temperature	T_O	0	+70	°C	
Power Supply Voltage	V_{CC}	-0.5	3.7	V	

MXPD-245MD (1550nm DFB and PIN, 40km, Monitoring function)
Transmitter Optical, Electrical Characteristics

Parameter	Symbol	Min.	Typ.	Max.	Unit	Note
Input Differential Impedance	R_{in}		100		Ω	
Transmitter Differential Input Voltage	$V_{in PP}$	500		1200	mV	
Transmit Disable Input High Voltage		2.0			V	
Transmit Disable Input Low Voltage				0.8	V	
Transmit Fault Output High Voltage		2.0			V	
Transmit Fault Output Low Voltage				0.8	V	
Transmit Disable Assert Time			0.14	5	μs	
Optical Transmit Power	P_O	-5		0	dBm	Average Power
Extinction Ratio	ER	9			dB	
Central Wavelength	λ_c	1530	1550	1580	nm	
Output Spectrum Width (-20dB)	$\Delta\lambda$			1	nm	
Side Mode Suppression Ratio	SMSR	30			dB	

Receiver Optical, Electrical Characteristics

Parameter	Symbol	Min.	Typ.	Max.	Unit	Note
Receiver Differential Output Voltage	$V_{out PP}$	400		1600	mV	
Receiver Loss of Signal Output Voltage -High		2			V	
Receiver Loss of Signal Output Voltage -Low				0.8	V	
Sensitivity	Sen			-23	dBm	BER<1E-12
Maximum Input Power	P_{inMAX}	-3			dBm	
Signal Detect Range		-35		-24	dBm	
Signal Detect-Hysteresis		0.5			dB	
Central Wavelength	λ_c	1280		1620	nm	

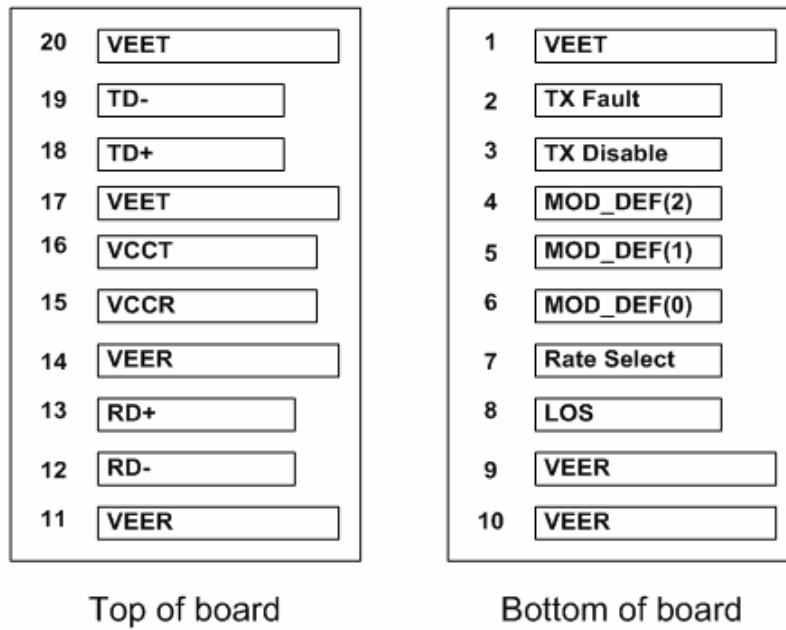
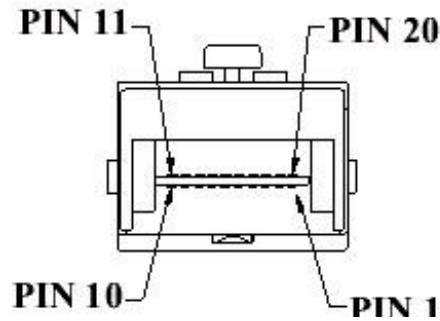
Pin Definition:

Figure1
Pin Assignment:

Figure2

Pin	Name	Description
1	VEET	Transmitter Ground
2	TXFAULT	Transmitter Fault.
3	TXDIS	Transmitter Disable.
4	MOD_DEF(2)	SDA Serial Data Signal
5	MOD_DEF(1)	SCL Serial Clock Signal
6	MOD_DEF(0)	Grounded within the module.
7	Rate Select	No connection required
8	LOS	Loss of Signal indication. Logic 0 indicates normal operation.

9	VEER	Receiver Ground
10	VEER	Receiver Ground
11	VEER	Receiver Ground
12	RD-	Receiver Inverted DATA out.
13	RD+	Receiver Non-inverted DATA out.
14	VEER	Receiver Ground
15	VCCR	Receiver Power Supply
16	VCCT	Transmitter Power Supply
17	VEET	Transmitter Ground
18	TD+	Transmitter Non-Inverted DATA in.
19	TD-	Transmitter Inverted DATA in.
20	VEET	Transmitter Ground

Block Diagram Of Transceiver

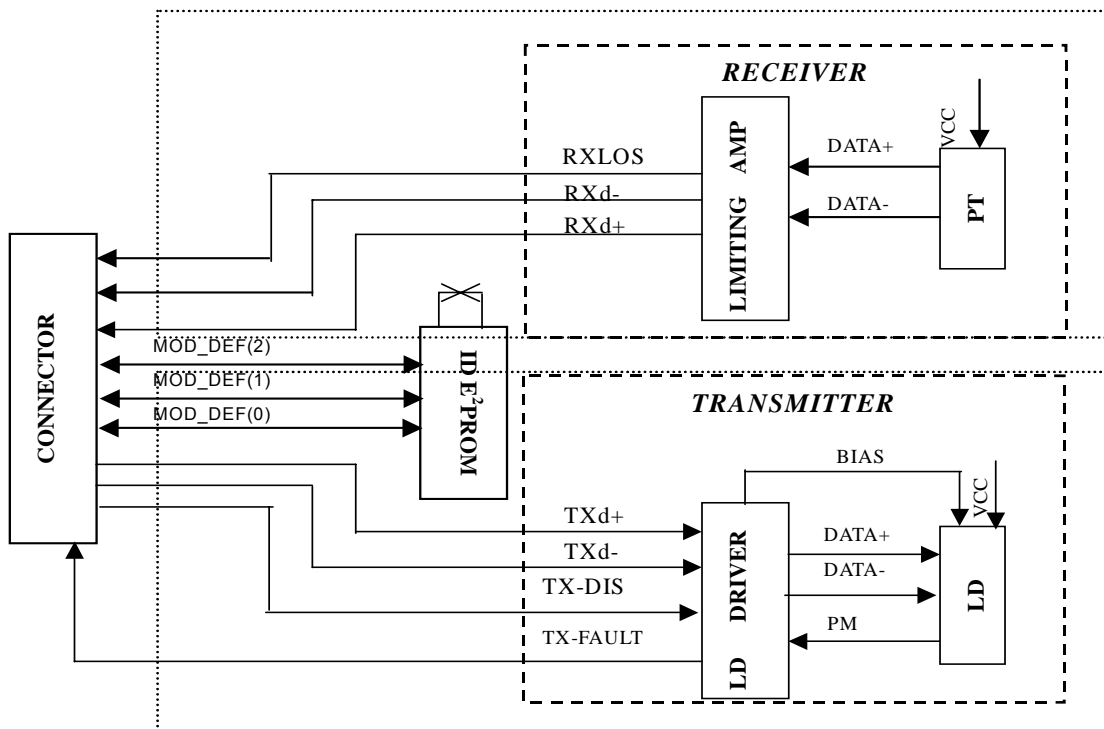

Figure3

Transmitter Section

TX-FAULT

TX Fault is an open collector/drain output, which should be pulled up with a 4.7K – 10K Ω resistor on the host board. Pull up voltage between 2.0V and VccT, R+0.3V. When high, output indicates a laser fault of some kind. Low indicates normal operation. In the low state, the output will be pulled to < 0.8V.

When sensing an improper power level in the laser driver, the SFP sets this signal high and turns off the laser. TX-FAULT can be reset with the TX-DISABLE line. The signal is in TTL level.

TX-DISABLE

TX disable is an input that is used to shut down the transmitter optical output. It is pulled up within the module with a 4.7 – 10 K Ω resistor. Its states are: Low (0 – 0.8V): Transmitter on; (>0.8, < 2.0V): Undefined; High (2.0 – 3.465V): Transmitter Disabled; Open: Transmitter Disabled. The TX-DISABLE signal is high (TTL logic “1”) to turn off the laser output. The laser will turn on when TX-DISABLE is low (TTL logic “0”).

TD-/+

These are the differential transmitter inputs. They are AC-coupled, differential lines with 100 Ω differential termination inside the module. The AC coupling is done inside the module and is thus not required on the host board. The inputs will accept differential swings of 500 – 2400 mV (250 – 1200 mV single-ended), though it is recommended that values between 500 and 1200 mV differential (250 – 600 mV single-ended) be used for best EMI performance.

Receiver Section

RX-LOS

LOS (Loss of Signal) is an open collector/drain output, which should be pulled up with a 4.7K – 10K Ω resistor. Pull up voltage between 2.0V and VccT, R+0.3V. When high, this output indicates the received optical power is below the worst-case receiver sensitivity (as defined by the standard in use). Low indicates normal operation. In the low state, the output will be pulled to < 0.8V.

The RX-LOS is high (TTL logic “1”) when there is no incoming light from the companion transceiver. This signal is normally used by the system for the diagnostic purpose. The signal is operated in TTL level.

RD-/+

These are the differential receiver outputs. They are AC coupled 100Ω differential lines which should be terminated with 100 Ω (differential) at the user SERDES. The AC coupling is done inside the module and is thus not required on the host board. The voltage swing on these lines will be between 370 and 2000 mV differential (185 – 1000 mV single ended) when properly terminated.

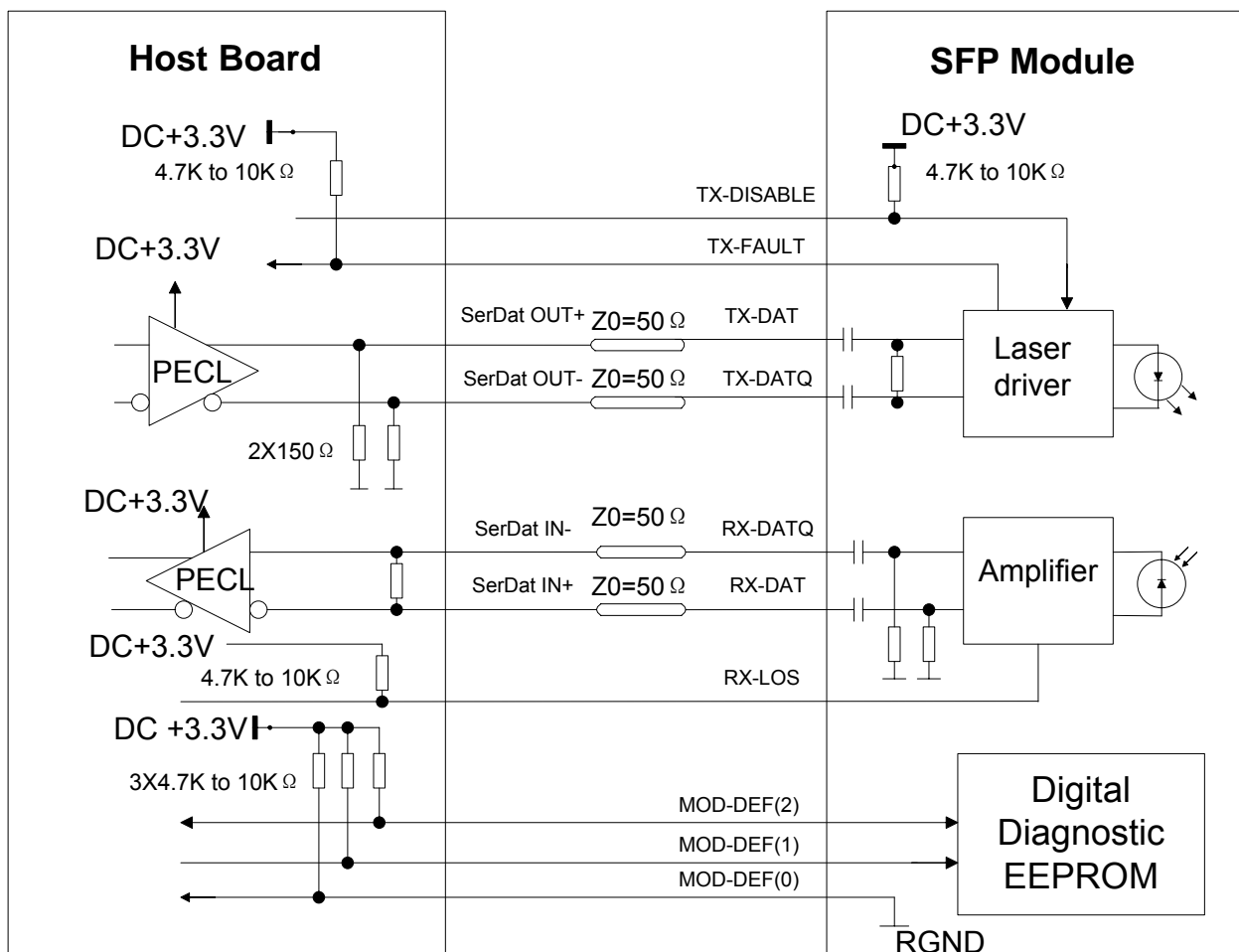
Recommended Interface Circuit:

Figure4

Dimensions:

Dimensions are in millimeters. All dimensions are $\pm 0.1\text{mm}$ unless otherwise specified. (unit:mm).

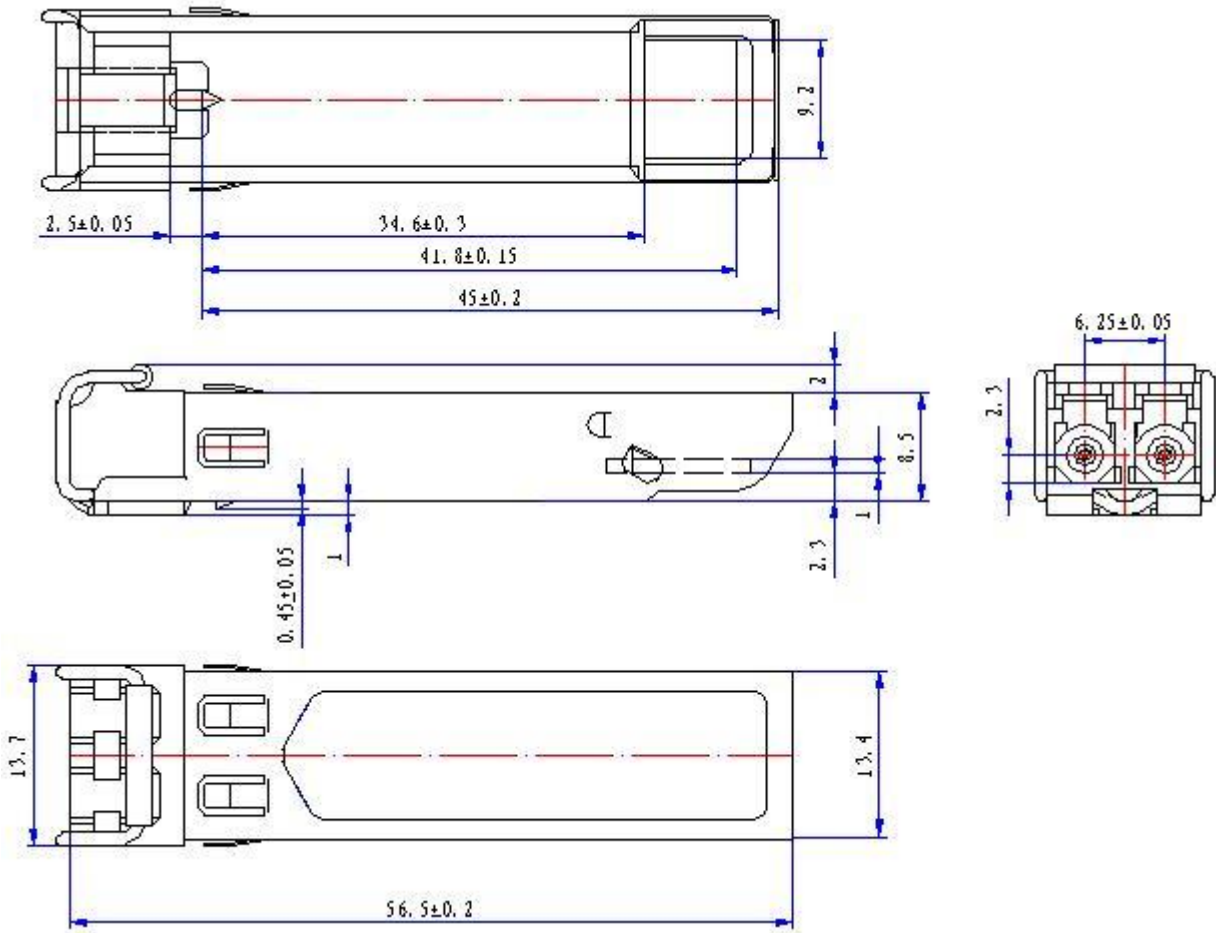
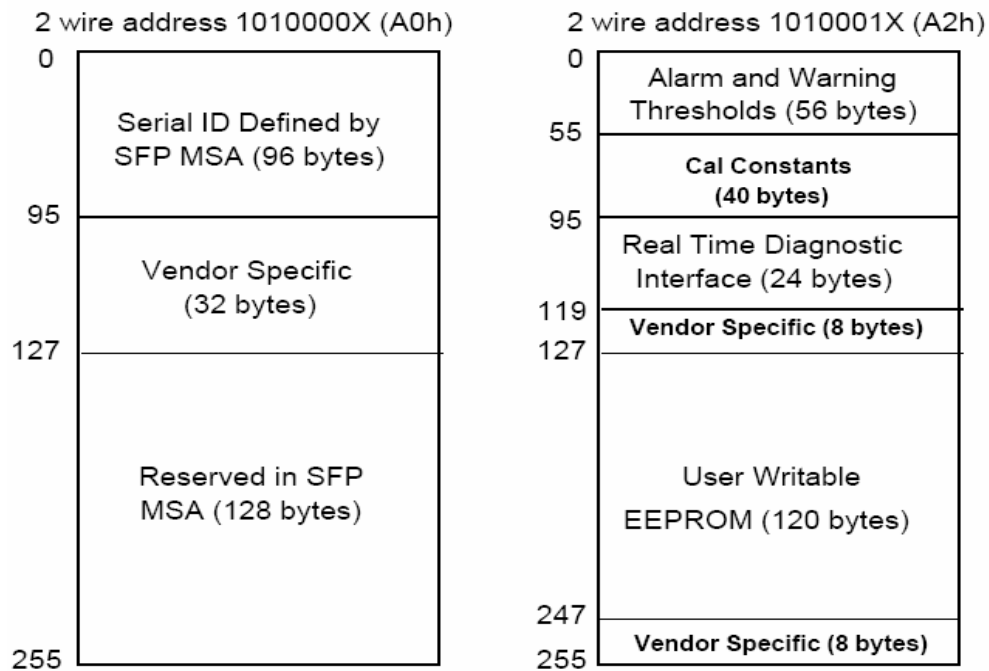

Figure5

Digital Diagnostic Memory Map:

EEPROM Serial ID Memory Contents:

Accessing Serial ID Memory uses the 2 wire address 1010000X (A0). Memory Contents of Serial ID are shown in the table below:

MXPD-245MD (1550nm DFB and PIN, 40Km, Monitoring function)				
Data Address	Size (Bytes)	Name of Field	Contents(Hex)	Description
BASE ID FIELDS				
0	1	Identifier	03	SFP
1	1	Ext. Identifier	04	SFP function is defined by serial ID only
2	1	Connector	07	LC Connector
3-10	8	Transceiver	00 00 00 01 20 40 0C 01	Transceiver Codes
11	1	Encoding	01	8B/10B
12	1	BR, Nominal	0D	1250 Mbps
13	1	Reserved	00	
14	1	Length(9um,km)	28	Transceiver transmit distance (40km)
15	1	Length (9um)	00	
16	1	Length (50um)	00	Not compliant

17	1	Length (62.5um)	00	
18	1	Length (Copper)	00	Not compliant
19	1	Reserved	00	
20-35	16	Vendor name	48 47 20 47 45 4E 55 49 4E 45 20 20 20 20 20 20	"HG GENUINE" (ASCII)
36	1	Reserved	00	
37-39	3	Vendor OUI	00 00 00	
40-55	16	Vendor PN	4D 58 50 44 2D 32 34 35 4D 44 20 20 20 20 20 20	"MXPD-245MD" (ASCII)
56-59	4	Vendor rev	00 00 00 00	
60-61	2	Wavelength	05 1E	Transceiver wavelength
62	1	Reserved	00	
63	1	CC_BASE	Check Sum (Variable)	Check code for Base ID Fields
EXTENDED ID FIELDS				
64-65	2	Options	00 1A	TX_DISABLE, TX_FAULT and Loss of Signal implemented.
66	1	BR, max	00	
67	1	BR, min	00	
68-83	16	Vendor SN	20 20 20 20 20 20 20 20 38 37 36 35 34 33 32 31	Serial Number of transceiver (ASCII). For example "87654321"
84-91	8	Date code	30 34 31 32 30 35 20 20	Manufactory date code. For example "041205"
92	1	Diagnostic Monitoring Type	58	Diagnostics (Ext.Cal)
93	1	Enhanced Options	B0	Diagnostics (Optional Alarm/warning flags,Soft TX_FAULT and RX_LOS monitoring)
94	1	SFF-8472 Compliance	02	Diagnostics (SFF-8472 Rev 9.4)
95	1	CC_EXT	Check Sum (Variable)	Check sum for Extended ID Field.
VENDOR SPECIFIC ID FIELDS				
96-255	160	Vendor Specific		

Digital Diagnostic Monitoring Information:

Parameter	Range	Actual Value	Note
Transceiver Temperature	0~70°C	±3°C	1
Power Supply Voltage	2.85~3.7V	±3%	2
Tx Bias Current	1~100mA	±10%	
Tx Optical Power	-5~0dBm	±3dB	
Rx Optical Power	-26~-3dBm	±3dB	

Note:

1. Temperature is measured internal to the transceiver.
2. Voltage is measured internal to the transceiver.

Ordering Information:

Digital Transceiver Denominate Rule

MXPD — X₁X₂X₃X₄X₅ — X₆

SFP Module with
DDMI

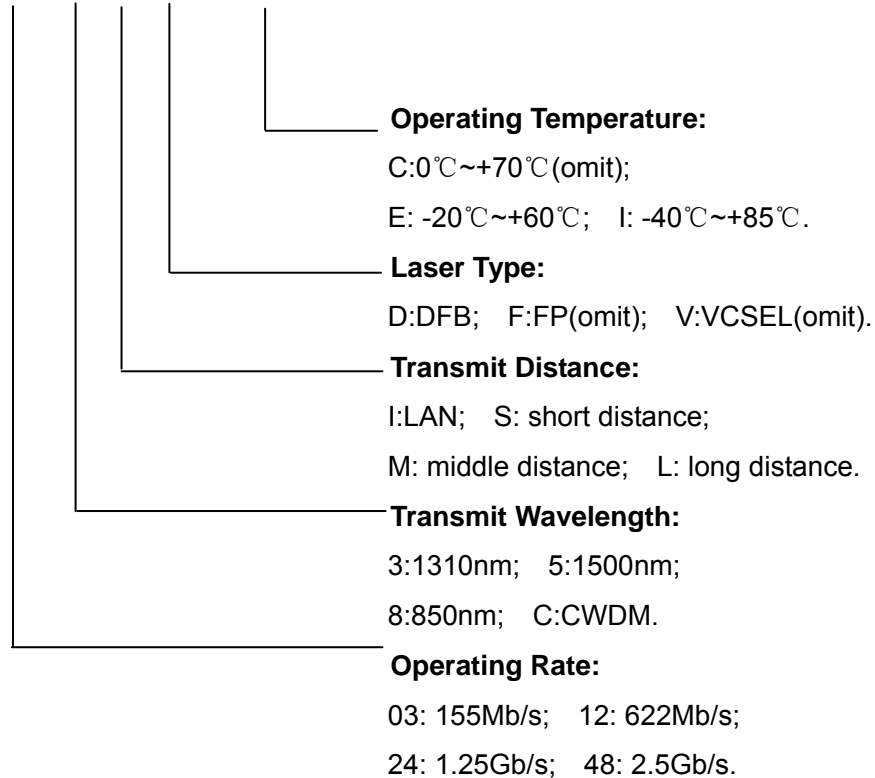
Statement:

HG Genuine possesses the authority for ultimate explanation of all information contained in this document, which is subject to change without prior notice. All the information was obtained in specific environments; and HG Genuine will not be responsible for verifying the products performance in customers' operating environments, neither liable for the performance of users' products. All information contained is only for the users' reference and shall not be considered as warranted characteristics. HG Genuine will not be liable for damages arising directly or indirectly from any use of the information contained in this document.

Version: **V1.1**

Publishing Date: 2007-01-08

Contact Information:

Address: HUST Science & Technology Park, East Lake Hi-Tech Development Zone, Wuhan, Hubei 430223, China.

Tel: +86-27-87180102

Website: <http://www.genuine-opto.com>

Tel:(86)27-8718-0102 Fax:(86)27-8718-0220 Email:market@genuine-opto.com